

Power Skiving Unit

High Productive Manufacturing of ID/OD Gears and Splines with CNC Turning Centers.

Maximum flexibility, high quality, optimal handling.

In operation:



Power Skiving Unit for ID and OD

Ratio i (n1:n2)	1:1
Max. RPM (n2)	3,000
Max. torque M	63 Nm
Max. scale swing α	$\pm 45^\circ$
Tool clamping dia.	$\varnothing 20$ DIN1835A
Coolant supply	internal a. external
Max. coolant pressure	1160 PSI (80 bar)
Required coolant filtration	$\leq 50 \mu\text{m}$



- | High stiffness and runout accuracy
- | Quick cutting tool change with hydro chuck

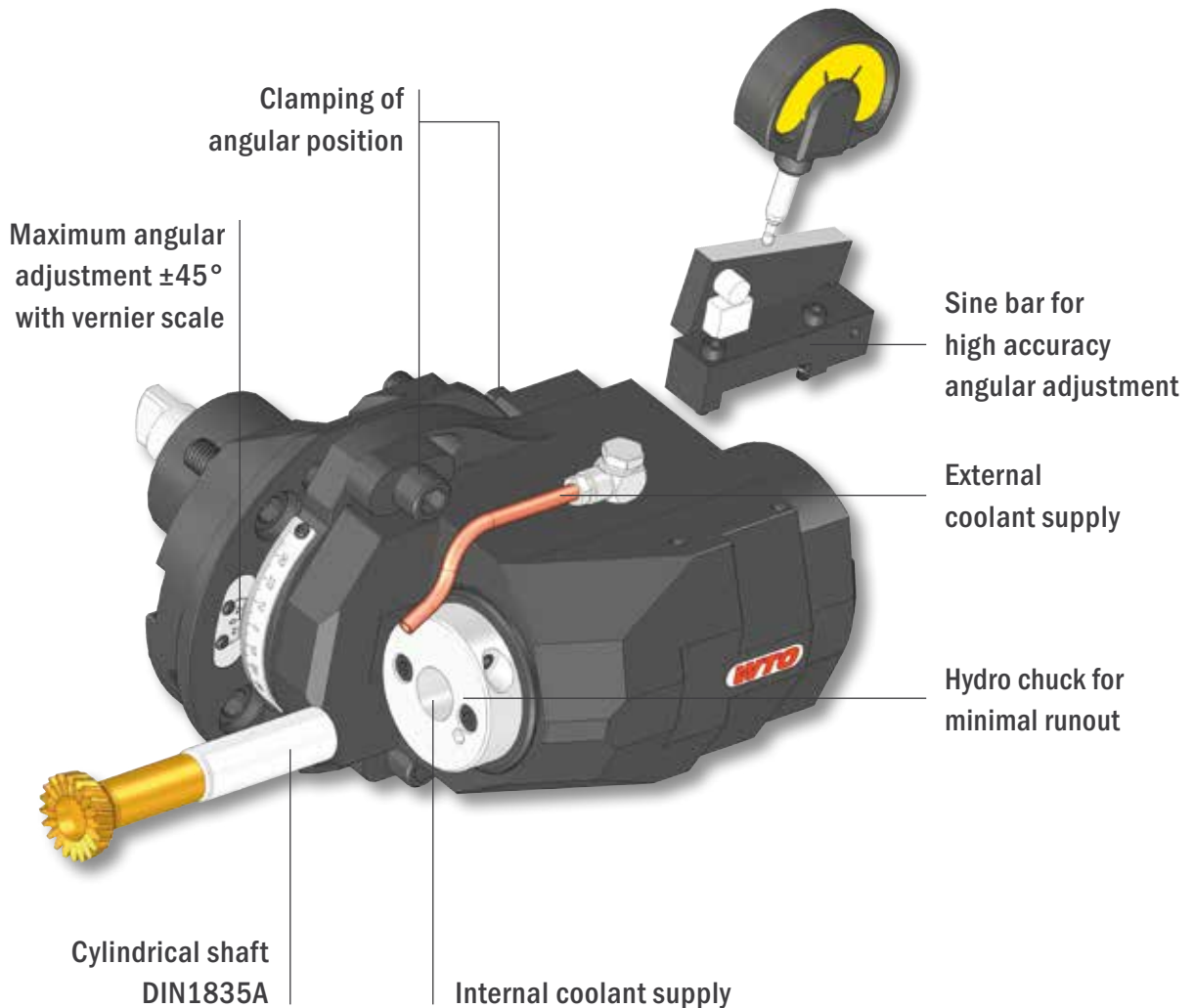

Operation principle: Power Skiving

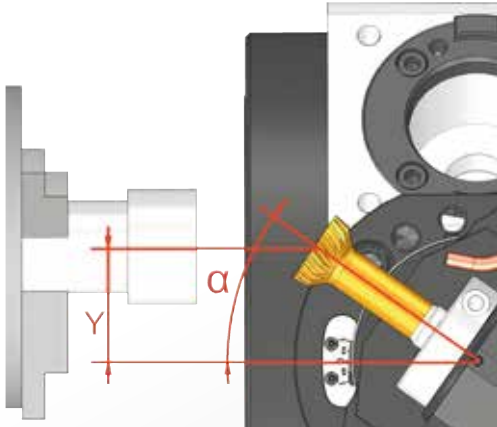

The workpiece axis and the skiving tool axis must be related to each other in a defined angle (α).

The offset of the cutting tool (Y) caused by rotating to the defined angle (α) must be compensated with the Y-axis of the machine.

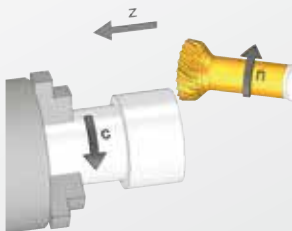

Synchronization of work piece and tool rotation.

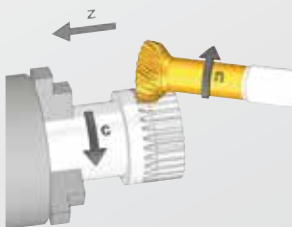

Feed movement in Z-axis.

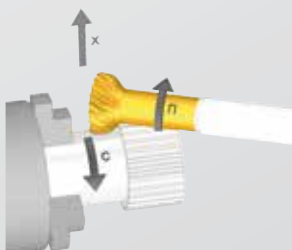

When skiving is finished the cutter has to move towards X.

Please consider:

At the end of the gear/spline there must be sufficient clearance for the cutter.

Sample workpieces



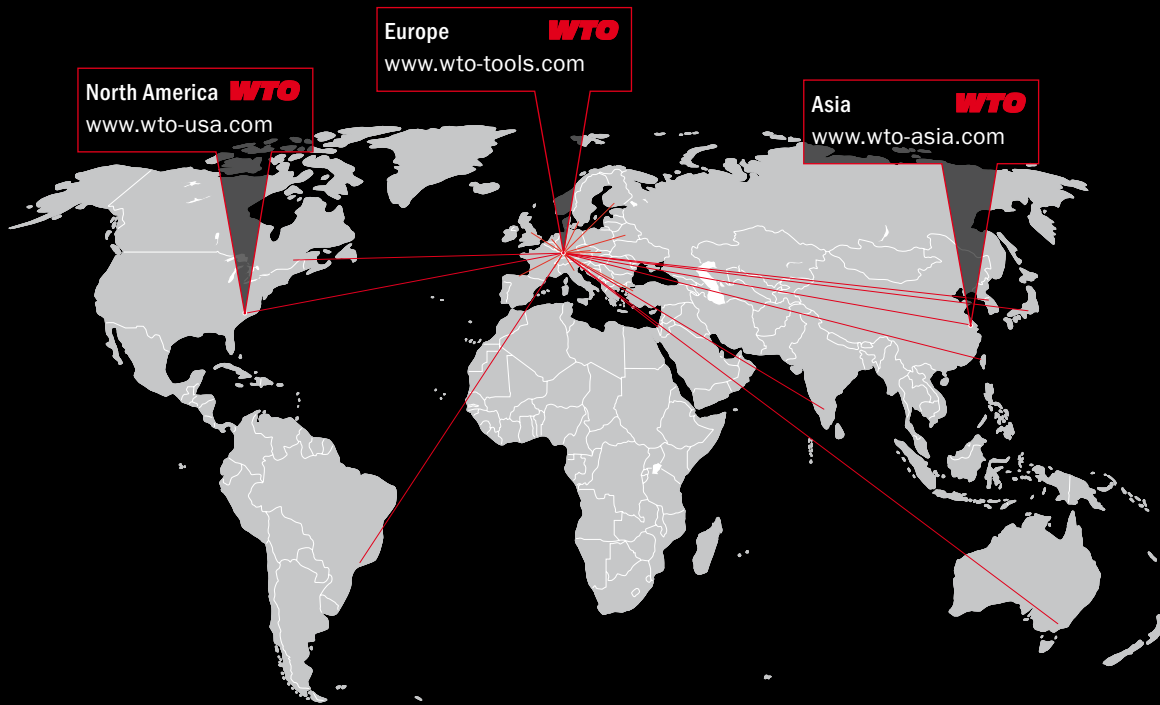

WTO Werkzeug-
Einrichtungen GmbH
Neuer Hohdammweg 1
77797 Ohlsbach
Germany

WTO Inc.
9210 Porters View Dr.
Charlotte, NC 28273
USA

WTO Asia
WTO Precision Tool Holders
(Shanghai) Co. Ltd.
Room 109-110, Building 2
No. 228 Banting Road
Jiuting Town,
Songjiang District
201615 Shanghai
China

Our distribution partners. Competence right there.

Australia
Dimac Tooling Ltd.
sales@dimac.com.au

Brazil
TF2
tfdois@tfdois.com.br

Canada
Mittmann Industrial Inc.
info@mittmann.com

China
Shanghai Gangde
wtocando@yahoo.com

Czech Republic
ALBA precision, spol. s.r.o.
info@albaprecision.cz

Denmark
AVN Teknik A/S
cjo@avn.dk

Finland
Suomen Terätuonti Oy
myynti@stt.as

France, east
Christophe Archambault
alm@wto.de

France, west
Christophe Archambault
car@wto.de

Great Britain
Cutwel Ltd.
sales@cutwel.net

Hungary
Prevotex Hungary Kft.
info@prevotex.hu

India
Ulhas Patil
u.patil@wto-asia.com

Israel
E.Y.A.R. Ltd.
boris@eyar.co.il

Italy
Prymark srl
commerciale@prymark.it

Japan
NK Works Co. Ltd.
k_samba@nk-works.co.jp

Korea
WTO Office Korea
is.chon@wto-korea.com

Mexico
Workholding Engineering De México
info@wem.com.mx

Netherlands
Toologic BeNeLux B.V.
info@toologic-benelux.nl

Norway
Helge Karlsen Verktøy og Maskin AS
hkvm@hkvm.no

Poland
ARCO Andrzej Rudenko
info@arcotools.pl

Romania
SC Elif Trading SRL
bulent.ozkan@eliftrading.com

Slovakia
ALBA precision s.r.o.
albaprecision@albaprecision.sk

Spain
ITALMATIC, S.A.
italmatic@italmatic.es

Sweden
Bonhron & Ewing AB
info@bonhron-ewing.se

Switzerland
Utilis AG
info@utilis.com

Taiwan
Kaiko Co., Ltd.
info@kaiko.com.tw

Turkey
MYK CNC MAKINA SAN. VE
huseyin.tatlidil@mykcnc.com.tr

Ukraine
„LLC“ SPA Stankopromimport
info@phoenix-ua.com